





<p>(A)</p>  <p>M5X45mm 8+1pcs</p>	<p>(B)</p>  <p>φ 3. 5X25mm 4+1pcs</p>
<p>(1)</p>  <p>1pc</p>	<p>(2)</p>  <p>1pc</p>
<p>(3)</p>  <p>1pc</p>	<p>(4)</p>  <p>1pc</p>
<p>(5)</p>  <p>1pc</p>	

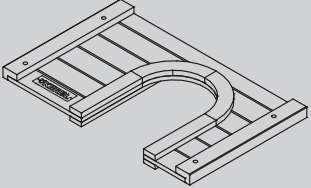
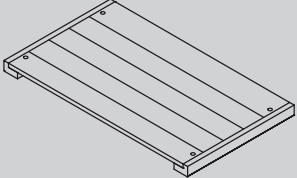
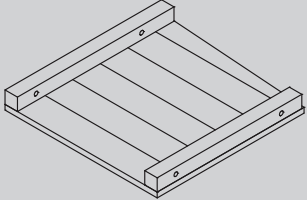
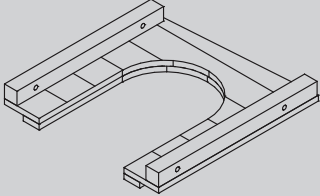
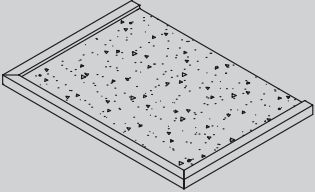
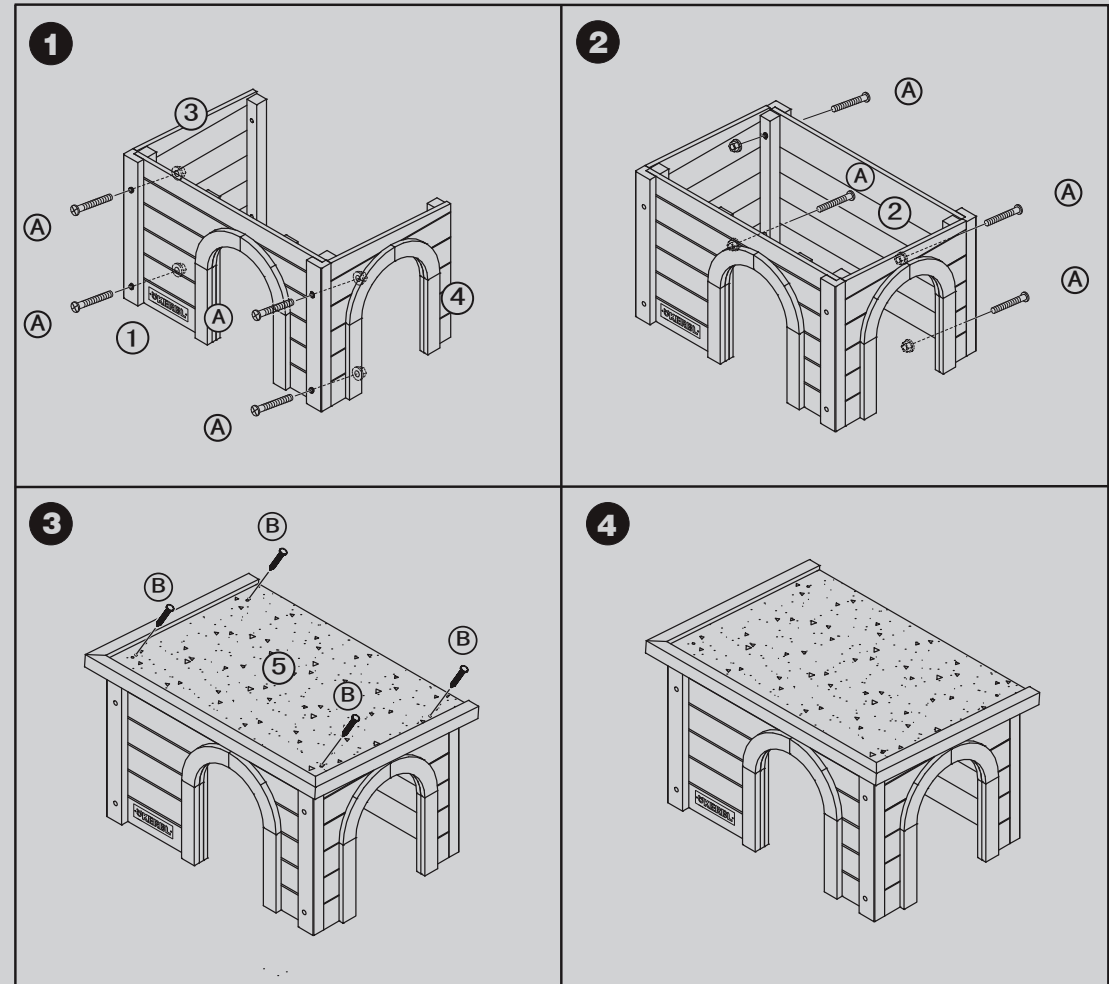

(DE) Um die Lebensdauer des Stalles zu verlängern, sollte das Holz mit geeignetem Anstrich nachbehandelt werden.

(EN) In order to enhance life expectancy it is advisable to treat the wood with an appropriate additional coating.

(FR) Pour augmenter la durée de vie de ce produit il convient de réaliser un traitement complémentaire avec une teinture similaire.

(IT) Per prolungare la vita della stalla bisogna ancora trattare il legno con una verniciatura adatta.